Three-Phase Electric Power Distribution for Computer Data Centers

WHITE PAPER - EP901

Mark Germagian
Opengate Data Systems
January 2008

Summary

This paper will describe the characteristics of three-phase power and outline the advantages of distributing power with a three-phase circuit for power transmission, in general, and more specifically in the distribution of power in a computer data center facility. The advantages of three-phase power distribution will be compared to single-phase distribution and metrics for comparison will be presented and clearly explained for the purpose of understanding costs and the flexibility for a growing and changing data center environment.

Benefits of three-phase circuits for power distribution

Multiple three-phase shifts are created at the power generation station. The AC generator's rotating magnetic field passes three sets of independent windings, each of which is 120 degrees apart.

A three-phase power circuit, also referred to as a polyphase (more than one phase) circuit, provides more power for the same current than would a single-phase circuit. Three-phase circuits are used in power distribution systems for the following reasons;

- Higher power transmission for the same electric current
- Less copper required for the same power transmission
- Safer or lower voltages transmitted due to multiple phases
- Reduced need for hot work on panel due to more available power and multiple voltage options

The advantages of a three-phase power distribution system over a single-phase system can be demonstrated in the following circuits. For purposes of comparison, both circuits will maintain an equivalent power capacity and load.

A single-phase system with three 5 kVA loads connected directly in parallel has a conductor current of 125 amps.

To carry this 125 amp load a single copper conductor, while observing NEC Article 310-16 at 75° C, would need to be 1 AWG. The weight of copper in this 1 gauge wire is roughly 32 pounds per 100 foot of conductor length and at \$3.40 per pound for copper has a total cost of \$109 for 100 feet of bare copper material. Processing costs for the conductor and insulator would be significantly higher.

In comparison, a three-phase system with three 5 kVA loads connected directly in parallel has a conductor current of 42 amps. This is significantly less than the 125 amps required for the conductor of a single phase system.

To carry the 42 amp load, the copper conductor would need to be 8 AWG. This 8 gauge wire

Figure 1



Three-phase power transmission

Figure 2

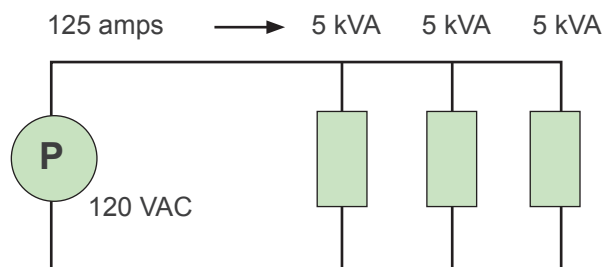

Amperage in a single-phase circuit

Figure 3

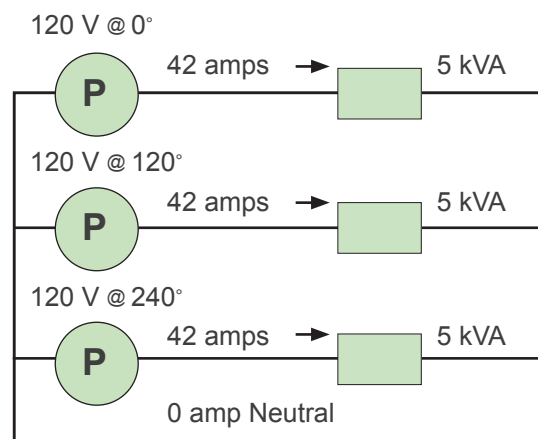

Amperage in a three-phase circuit

weight is about 5 pounds per 100 feet and a total cost of \$17 for the bare copper material.

The three-phase circuit that we have

demonstrated would require an additional conductor over a single-phase circuit. The following copper weight and cost is adjusted for this additional conductor and is shown in Table 1:

Table 1

15 kW Total Load	Single-phase	Three-phase
Conductor Current	125 mps	42 amps
Conductor Gauge	3 x 1 AWG	5 x 8 AWG
Conductor Weight (100 ft)	96 pounds	25 pounds
Conductor Cost (100 ft)	\$327 USD	\$85 USD

Conductor weight and cost comparison for single versus three-phase transmission

Note: Single phase shown uses 3 wires (Hot-Neutral-Ground). Three-phase allows only 208V output and uses 4 wires (Hot-Hot-Neutral-Ground). A three-phase system that allows 120V and 208V output uses 5 wires (Hot-Hot-Hot-Neutral-Ground).

Note: All costs at time of pricing

A three-phase system delivers more power with smaller gauge conductors than a single-phase system of the same amperage. The benefits of this are;

- Lower copper cost
- Fewer circuit breaker pole positions for 208V loads
- Lower labor and equipment to handle and manage lighter copper
- Lower system voltage for a safer work environment

Three-phase systems achieve greater conductor

efficiency and reduce the safety risks by breaking the total voltage into additional parts and by powering multiple loads at these lower voltages.

Another important benefit of three-phase power over single-phase power is the ability to efficiently run AC motors and pumps in a facility. Each conductor is carrying the same current at the same frequency but reach their instantaneous peak values at different times in the phase cycle. This is effective in creating an efficient rotating magnetic field for an electric motor because each phase is delayed by 1/3 of the total phase cycle and provides a constant power source to the load.

Anatomy of Three-Phase Power and Transmission

In general, there are two types of three-phase circuits, a Delta three-phase and a Wye three-phase circuit. It is not necessary for a three-phase circuit to have a neutral wire. The purpose of a neutral wire allows 120V devices to be used from a three-phase circuit.

For a high voltage transmission this neutral wire is not commonly present and high voltage loads are connected across the hot (phase) conductors. The phase currents will cancel each other, summing to zero for a linear balanced load, which is desirable for electric power systems.

An electric generator converts mechanical rotation into alternating current. As we touched on earlier, the electric generator at the power station will generate the electric currents that are the same frequency but offset by 120° to provide the three phases. This system typically creates voltages up to 30,000 volts and step-up transformers are used to make this voltage desirable for efficient transmission.

Typical three-phase transformers are star or Wye connected. Another system, more common to North America is a Delta circuit where the center tap on one winding supplies the ground. The Wye and Delta three-phase circuits are

demonstrated in Figure 4. Wye circuits are more commonly found in data center environments, while Delta configurations are more common in heavy industrial and manufacturing environments. The Wye circuit provides two different supply voltages for each phase or leg of the circuit. Poly-phase loads are connected phase-to-phase and single phase loads are connected phase-to-neutral. Phase unbalance current would be carried by the neutral conductor for a Wye circuit. The line amperage in a Wye circuit is equivalent to the phase amperage where the phase-to-phase voltage is 1.73 or $\sqrt{3}$ times the phase-to-neutral voltage. A few typical Wye circuit voltages are 120/208Y, 277/480Y, 2400/4160Y, and 7200/12470Y.

Phase-to-phase connection for higher power devices is usually accomplished with a two-pole breaker. For instance, a single phase line to line circuit with 208 Volt potential will provide 1.73 times more power for the same 120V line to neutral single phase connection while using the same conductor size. The sinusoidal wave form of a three-phase circuit is demonstrated in Figure 5.

For each of the conductors in a three-phase cable, color coding for the conductor insulator jacket for US and Canada usually follows the guidelines shown in Table 2:

As we continue to uncover the advantages of three-phase power distribution to reduce costs,

Figure 4

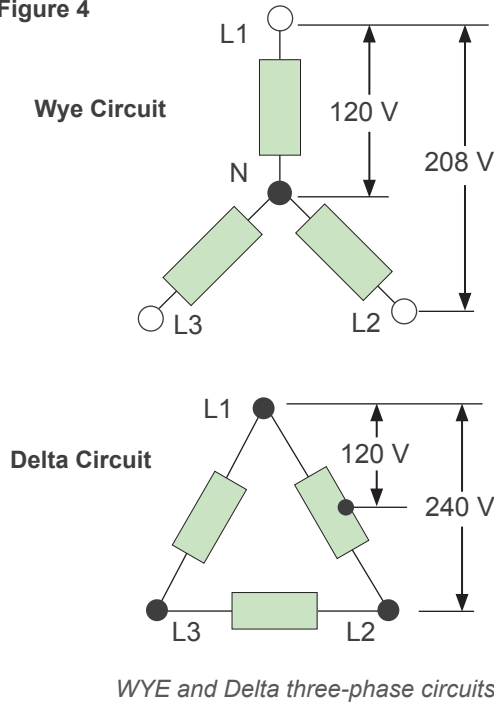

Figure 5

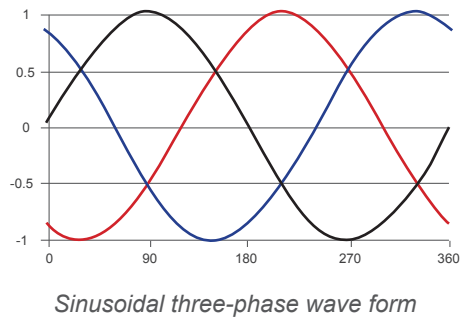

Table 2

Location of Standard	L1 - L2- L3	Neutral - Ground
United States (common practice)	Black - Red - Blue	White or Gray - Green
Canada (mandatory)	Red - Black - Blue	White - Green
United States (alternative)	Brown - Orange - Yellow	White or Gray - Green
Canada (isolated cases)	Orange - Brown- Yellow	White - Green

Conductor jacket color coding for US and Canada.

provide flexibility for a growing and changing data center environment and for the need to balance power loads for the entire data center facility, only Wye circuits will be discussed as this is the typical circuit used in data center facilities throughout North America.

A UPS can typically be configured to output 208 or 480VAC. Downstream from the UPS a PDU may be utilized to drop a UPS output of 480V to 208V for further distribution to the IT equipment load. The two schemes mentioned have been simplified and demonstrated in Figure 6.

IT equipment power loads and varying power standards effecting power distribution strategies

Just a few years ago, it was common to distribute power from the UPS to the IT equipment load in the US with 120VAC. A breaker panel, similar to the one in your home, receiving a 120V input and distributing this in multiple 120V, single pole breakers to the IT load is still common to see. Each 120V single pole breaker provides a single feed to each rack in the data center. The continued use of 120V power distribution in data centers reduces efficiency of IT operations and increases the use of copper.

Today, the most common distribution standards are 208V and 208V three-phase. Modern IT equipment is designed and sold for global use. For example; the common equipment voltage for North America is 120V or 208V, in Japan the standard is 100V or 200V and for most of the rest of the world, the voltage standard is 230-240V.

IT equipment being delivered today will typically accept a full range of 96V-264V input. It is important to note that many blade server chassis and some large network switches will only accept 208V because their higher power requirements cannot be met with 120V input. With the need for higher power that only 208V can provide and the need for multiple voltage flexibility to power some 120V devices, a single 208V three-phase branch circuit provides the needed voltage output flexibility.

An accurate estimation for average rack power loads can be difficult to attain. Based on a survey poll as shown in Figure 7, average rack loads have increased to where 30% are indicating that the average rack load in their facility is now 6-10 kW. Any power distribution scheme should aim to

Figure 6

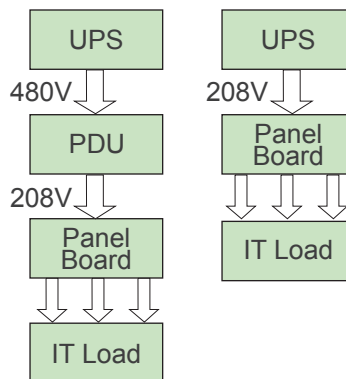

Two typical power flow diagrams for UPS to the IT equipment load.

Figure 7

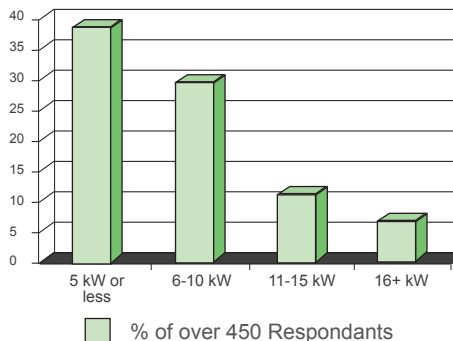

Average rack loads based on a Data Center Decisions Poll from October 2007

provide a reduced number of circuits for overall reliability and reduction in copper runs. Table 3 demonstrates the number of required circuits for varying rack loads using different rack power distribution standards.

Table 3

IT Rack Equipment Load*	REQUIRED CIRCUIT QUANTITY			
	120V 30A	208V 30A	208V 3PH 30A	208V 3PH 80A
3 kW	2	2	2	2
5 kW	4	2	2	2
9 kW	6	4	2	2
17 kW	12	8	4	2
23 kW	16	10	6	2

Circuit quantity for a variety of IT equipment rack loads. *Rack circuits are doubled for redundant feeds.

Typical three-phase PDU to IT equipment distribution schemes

With modern HD and Blade equipment having a variety of cable inputs, the default standard at the rack power strip is typically IEC C19 receptacles. With few exceptions, if a IT equipment manufacturer uses a special server plug or cord, the equipment manufacturer will supply a conversion cord to take the plug type to an IEC C13 or IEC C19 depending on maximum power draw. The following are two examples of power distributed to racked equipment.

HP C-class Power offers three variations for the power connection:

1. Single-phase IEC C19-C20 power connection
2. Three-phase L15-30 power connection
3. Three-phase IEC309 5 pin 16A connection

The example to the right represents the power distribution scheme for three-phase power to the rack power strip and single phase from the strip to the IT equipment. The scenario has four HP C-class Blade Chassis connected to two 80A three-phase rack power strips. In this scenario, with one power supply failure on a chassis and A or B feed down, the chassis still retains power without tripping a power strip branch breaker.

IBM BladeCenter chassis connect to rack power strips with four C19-C20 power cords when redundant power supplies are installed. The chassis is divided into two power domains. Two power supplies represent domain one and the other two redundant power supplies represent domain two. Domain one powers blades 1-6 and Domain two power blades 7-14. The power supplies are load balancing and are capable of providing up to 4000W DC power.

If there is a power related failure and a single 2000W power supply is required to do all the work, then the BladeCenter management module will manage the power. If the impacted power domain is drawing more then 2000W, then the clock speed will be slowed to manage power below 2000W.

Figure 8

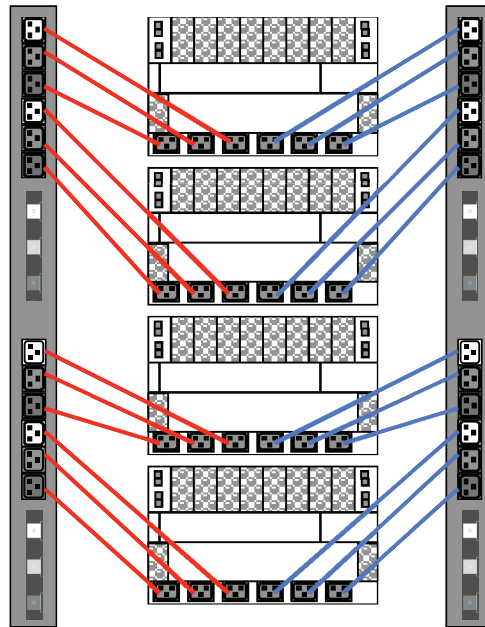

Power distributed to four HP C-class chassis.

Figure 9

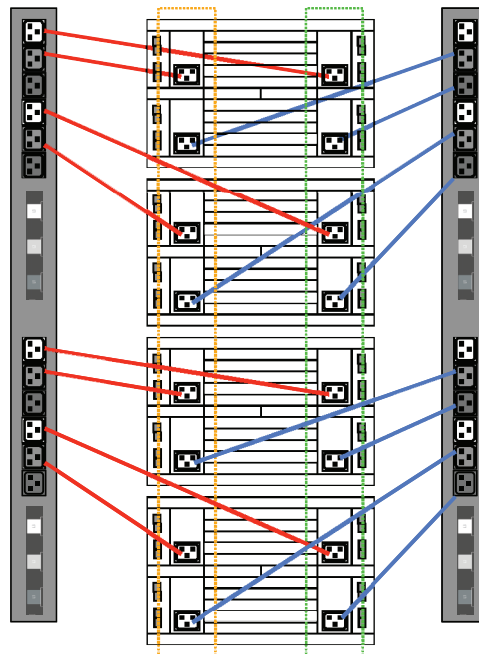

Power distributed to an IBM BladeCenter chassis

Conclusion

Three-phase circuits are used in power distribution systems to allow higher power transmission for the same electric current, require less copper for the same power transmission, are safer due to lower voltages transmitted over multiple phases and reduce the need for panel hot work due to more available power and multiple voltage options. Bringing three-phase to the rack will;

- Lower material and installation costs
- Lower installation time with fewer whips to pull
- Less wire under floor improves airflow and reduces wiring confusion and mistakes
- Simplify load balancing by balancing multiple devices across phases within the rack. With significant variation of load from rack to rack, it is almost impossible to balance phases once you leave the rack.

A three-phase system with a total 15 kW load and a conductor current of 42 amps is significantly less amperage than the 125 amps required for a conductor of a single phase system. A three-phase 100 foot 42 amp load has a conductor weight of 20 lbs. at a rough cost of \$70 USD versus a single-phase 100 foot 125 amp load with a weight of 96 lbs. at a rough cost of \$330 USD. A three-phase system delivers more power with smaller gauge conductors than a single-phase system of the same amperage with lower copper cost, fewer circuit breaker pole positions for 208V loads, lower labor and equipment to handle and manage lighter copper and lower system voltage for a safer work environment. Three-phase systems achieve greater conductor efficiency and reduce safety risks by breaking the total voltage into additional parts and by powering multiple loads at these lower voltages.

About the Author: Mark Germagian is currently serving as President for Opengate Data Systems with responsibility to lead the firm into new technology areas relating to effective and efficient data center operation. Mark has directed technology development and was a design engineer for 22 years with experience designing products for telecom and technical work environments as well as cooling distribution systems for computer data centers. Mark holds multiple U.S. and international patents and is a contributing author for ASHRAE TC9.9 datacom series publications.

Note 1: Since 1975, the U.S. National Electric Code does not specify coloring of phase conductors. It is common practice in many regions to identify 120/208Y conductors as Black/Red/Blue. Local regulations may amend the N.E.C.

Note 2: The U.S. National Electric Code does not specify coloring of phase conductors. It is common practice in many regions to identify 277/480Y conductors as Brown/Orange/Yellow. Local practice may amend the N.E.C. The US N.E.C. rule 517.160 (5) states these colors are to be used for isolated power systems in health care facilities. Color of conductors does not identify voltage of a circuit, because there is no formal standard.

Stevenson, William D., Jr. (1975) Elements of Power Systems Analysis, McGraw-Hill electrical and electronic engineering series, 3rd ed., New York: McGraw Hill

US National Electric Code